

Three-Center Bonds in Electron-Deficient Compounds. The Localized Molecular Orbital Approach

William N. Lipscomb

Gibbs Chemical Laboratory, Harvard University, Cambridge, Massachusetts 02138

Received December 18, 1972

Having more valence atomic orbitals than valence electrons, electron-deficient compounds present ambiguities in the use of the paired electron bond. Molecular orbitals, at least of stable neutral compounds, are filled usually with a substantial energy gap to the lowest unoccupied excited orbital. However, molecular orbitals based upon the molecular symmetry group are delocalized. Moreover, they are not readily transferable to chemically closely related molecules.

Here, we seek a middle ground: nearly transferable multicenter bonds. We derive localized molecular orbitals (LMO's) objectively from accurate self-consistent field (SCF) molecular orbital (MO) theory. We explore the limits of transferability of these LMO's in the boranes, carboranes, and their related ionic species. Finally, we only begin to ask how these LMO's restrict the compositions, geometries, and reaction pathways in this area of chemistry.

Localized Molecular Orbitals

Recent studies have considerably narrowed the gaps between resonance descriptions of these molecules^{1,2} and molecular orbital results.^{3,4} Extended Hückel theory, developed in this laboratory,^{4,5} has been related^{6,7,8} to rigorously defined SCF theory^{9,10} of complex molecules. Leaving aside the severe limitations of SCF theory when electron correlation¹¹ is important, we note that it yields good approximations to electron density and to properties derived from one-electron operators,¹²⁻¹⁴ like the dipole moment and nmr shielding constants.

Here, we start with symmetry MO's. Their conversion to localized chemical bonds is achieved by mixing MO's of different symmetries. For example, consider the double bond of ethylene, composed of a single σ bond and a single π bond. If we take the sum and difference of these two orbitals, we find two equivalent "banana" bonds, one above and the other

below the molecular plane (Figure 1). This transformation leaves the total molecular electron density and the total energy invariant.¹⁵⁻¹⁹ In one sense, it is a better description of electron-pair bonding, because (a) it maximizes the sum D of repulsions of electrons within the same MO, ϕ_R

$$D = \sum_k (kk|kk) = \sum_k \int \phi(i)\phi_k(j) \frac{1}{r_{ij}} \phi_k(i)\phi_k(j) dV_i dV_j$$

and (b) it minimizes both the exchange energy and the interorbital electron repulsion energy. We use this criterion below for obtaining localized bonds objectively from accurate and well-defined molecular orbital wave functions. Although we shall find that the three-center bond is alive and well, and residing in the laboratories of most boron chemists, we shall also find some important new developments.

How localized are these bonds, and how many centers occur in multicenter orbitals? Suppose that the LMO, ϕ^L , resulting from the localization procedure given above, has obvious large components over three centers, for example, two borons and a hydro-

- (1) W. N. Lipscomb, "Boron Hydrides," W. A. Benjamin, New York, N. Y., 1963.
- (2) I. R. Epstein and W. N. Lipscomb, *Inorg. Chem.*, **10**, 1921 (1971).
- (3) R. Hoffmann and W. N. Lipscomb, *J. Chem. Phys.*, **37**, 2872 (1962).
- (4) R. Hoffmann and W. N. Lipscomb, *J. Chem. Phys.*, **36**, 3489 (1962).
- (5) R. Hoffmann and W. N. Lipscomb, *J. Chem. Phys.*, **36**, 2179 (1962).
- (6) M. D. Newton, F. P. Boer, and W. N. Lipscomb, *J. Amer. Chem. Soc.*, **88**, 2353 (1966).
- (7) F. P. Boer, M. D. Newton, and W. N. Lipscomb, *J. Amer. Chem. Soc.*, **88**, 2361 (1966).
- (8) T. A. Halgren and W. N. Lipscomb, *Proc. Nat. Acad. Sci. U. S.*, **69**, 652 (1972); *J. Chem. Phys.*, **58**, 1569 (1973).
- (9) C. C. J. Roothaan, *Rev. Mod. Phys.*, **23**, 69 (1951).
- (10) G. G. Hall, *Proc. Roy. Soc., Ser. A*, **205**, 541 (1951).
- (11) For example, J. G. Gerratt and W. N. Lipscomb, *Proc. Nat. Acad. Sci. U. S.*, **59**, 332 (1967).
- (12) W. N. Lipscomb, *Advan. Magnetic Resonance*, **2**, 137, (1966).
- (13) R. M. Stevens, R. M. Pitzer, and W. N. Lipscomb, *J. Chem. Phys.*, **38**, 550 (1963).
- (14) W. N. Lipscomb, "Theoretical Chemistry Volume," W. Byers Brown, Ed., MTP International Review of Science, Medical and Technical Publishing Co., Ltd., Oxford, England, 1972, p 167.
- (15) J. E. Lennard-Jones, *Proc. Roy. Soc., Ser. A*, **198**, 1, 14 (1949).
- (16) G. G. Hall and J. E. Lennard-Jones, *Proc. Roy. Soc., Ser. A*, **202**, 155 (1950).
- (17) J. E. Lennard-Jones and J. A. Pople, *Proc. Roy. Soc., Ser. A*, **202**, 166 (1950).
- (18) J. E. Lennard-Jones and J. A. Pople, *Proc. Roy. Soc., Ser. A*, **210**, 190 (1951).
- (19) C. Edmiston and K. Ruedenberg, *Rev. Mod. Phys.*, **35**, 467 (1963).

William Lipscomb received his Ph.D. from the California Institute of Technology in 1946, after receiving a B.S. in Chemistry at the University of Kentucky. He spent several years at the University of Minnesota, and is presently Abbott and James Lawrence Professor of Chemistry at Harvard University. Areas of research interest include the relation of geometrical and electronic structures to chemical properties of molecules in theoretical, inorganic, organic, and biological chemistry. He is the 1972 recipient of the Peter Debye Award in Physical Chemistry.

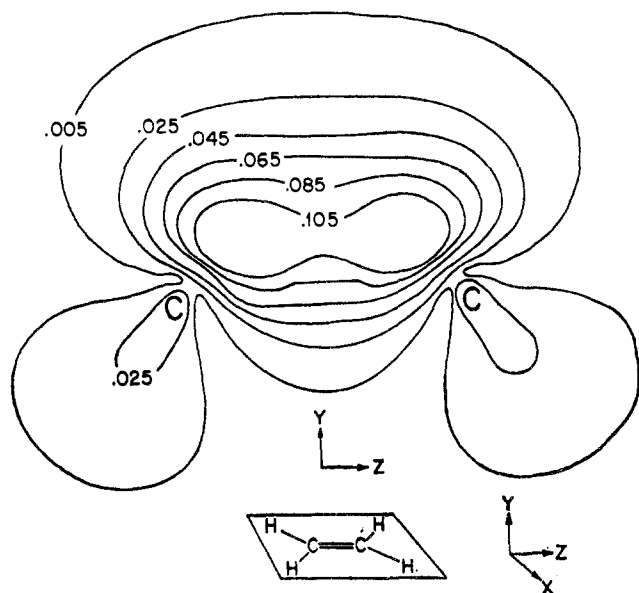

Figure 1. Localized C-C bond in ethylene. Contours are shown for the total density of one electron in electrons/au³, where 1 au = 0.529 Å.

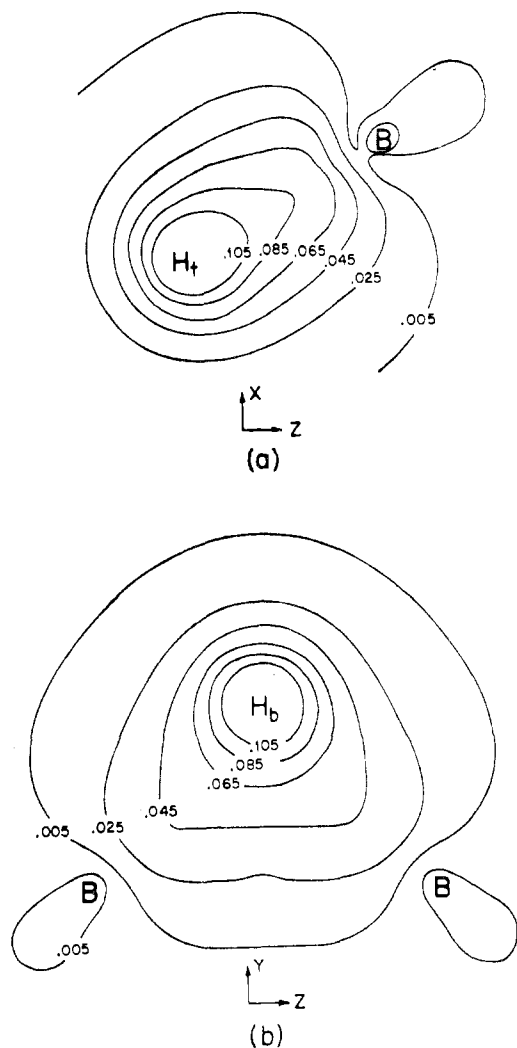

Figure 2. Density for one electron in electron/au³ for (a) the B-H (terminal) bond and (b) the B-H-B bond in B₂H₆.

gen of a bridge bond in diborane (Figure 2). It will also have small parts associated with all other atoms in the molecule. We obtain a truncated LMO, ϕ^T , by

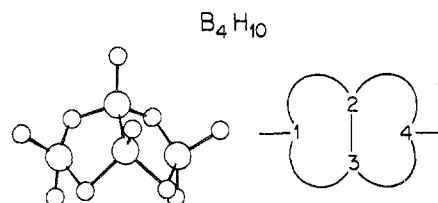

Figure 3. Geometrical and localized valence structure of B₄H₁₀. One terminal hydrogen is omitted from each boron (or, later, carbon) atom. The extra terminal H is indicated by a straight line, and the bridge hydrogen by a curved line.

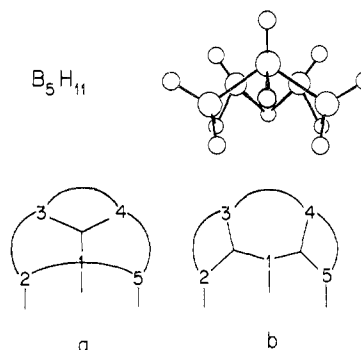

Figure 4. B₅H₁₁. Structure a, with an open three-center B(2)-B(1)-B(5) bond, is not favored by the localization, which yields central three-center bonds idealized in structure b.

omitting these small parts, and then renormalizing. Then the quantity^{20,21}

$$d = 100[\frac{1}{2} \int (\phi^L - \phi^T)^2 dV]^{1/2}$$

defines a percentage delocalization, zero if the LMO is completely localized on the centers assumed and 100% if ϕ^L and ϕ^T are completely orthogonal. We suggest, at present, that a center be omitted from ϕ^T if it contributes less than about 0.2 electron to ϕ^L .

Boranes and Carboranes

The three-center bond has been widely used in boron compounds.^{1,2,22,23} For example, in B₆H₁₀ there are 28 electrons and 34 valence orbitals. These 14 valence pairs may be accommodated in eight two-center bonds and six three-center bonds, thus accounting for all valence orbitals. The B₆H₁₀ structure has six terminal BH bonds and four hydrogen bridges. We then require two single BB bonds and two three-center BBB bonds. Similar rules apply to other boranes, carboranes, and their ions.

Some bonding arrangements are less favorable than others. For example, we exclude bonding of two adjacent B atoms by both a single bond and any type of three-center bond such as a bridge hydrogen, central BBB bond, or open BBB bond (see below). Even so, resonance hybrids are required for all but the simplest boranes (B₂H₆, B₄H₁₀) and carboranes. We show below that three-center bond theory is placed on a firm theoretical foundation²⁴ and that a

(20) E. Switkes, W. N. Lipscomb, and M. D. Newton, *J. Amer. Chem. Soc.*, **92**, 3847 (1970).

(21) M. D. Newton, E. Switkes, and W. N. Lipscomb, *J. Chem. Phys.*, **53**, 2645 (1970).

(22) H. C. Longuet-Higgins, *J. Chim. Phys. Physicochim. Biol.*, **46**, 275 (1949).

(23) W. H. Eberhardt, B. L. Crawford, Jr., and W. N. Lipscomb, *J. Chem. Phys.*, **22**, 989 (1954).

(24) E. Switkes, R. M. Stevens, M. D. Newton, and W. N. Lipscomb, *J. Chem. Phys.*, **51**, 2085 (1969).

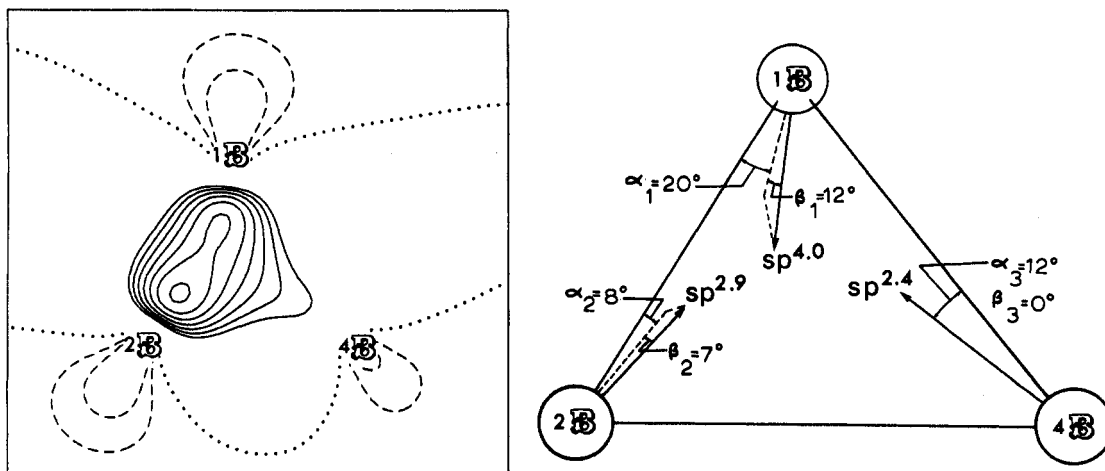

Figure 5. (a) One of the two localized three-center orbitals in the boron framework of B_5H_{11} . The electron density is obtained by squaring this function. (b) Hybrids resulting from the localization procedure.

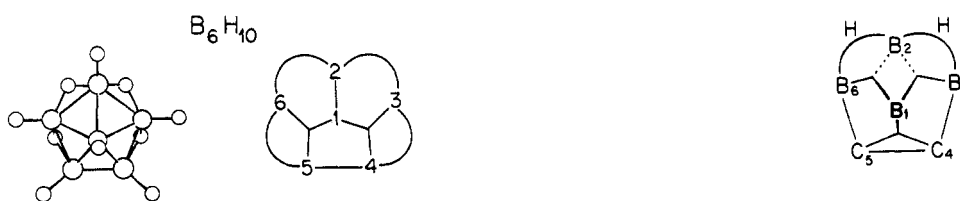

Figure 6. B_6H_{10} , which localizes uniquely.

new level of detail is obtained including distinctions between bonding rules between boranes and carboranes.

Bridge and terminal hydrogens, with a few interesting exceptions, are very similar in our LMO results. Their delocalization percentages (d) are about 14 and 10, respectively. For comparison, we observe that inner shells have percentages of 5.0, 4.5, 1.3, and 0.8 for B, C, N, and O, respectively. Central three-center BBB bonds range from 15 to 24%, and the bent bonds of ethylene (Figure 1), butadiene, and benzene have d values of 6, 8 and 19%, respectively.²⁵ We comment below on unusual d values.

Proceeding now to B_4H_{10} ²⁰ (Figure 3), B_5H_{11} ²⁰ (Figures 4 and 5), and B_6H_{10} ²⁶ (Figure 6), we see that in each case a single preferred valence structure occurs upon localization of each SCF wave function. In B_5H_{11} , the LMO's indicate a preference for central three-center BBB bonds (Figure 4b) over the structure involving an open three-center BBB bond (Figure 4a). The three-center bond itself is unsymmetrical (Figure 5a), having hybrids shown in Figure 5b. The unusual nonexternal H atom in the symmetry plane of B_5H_{11} is 20% delocalized toward B_2 and B_5 . Nevertheless, its bonding localizes as a terminal bond, even though it has some bridge properties.

The B_6H_{10} structure has isoelectronic analogs CB_5H_9 , $C_2B_4H_8$, $C_3B_3H_7$, and $C_2B_4H_8$. A LMO study²⁷ of $C_2B_4H_8$ shows two differences in bonding when compared to B_6H_{10} . First, the LMO's join the two carbons with both a single bond and a central three-center bond (Figure 7), a feature not, so far, found in boranes. Second, the LMO's give new

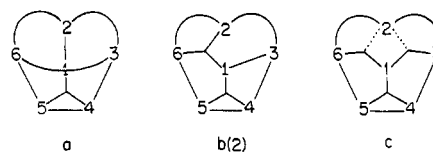

Figure 7. $C_2B_4H_8$, which localizes differently from B_6H_{10} and yields two fractional three-center bonds having partial orbital contributions to B_2 . Alternate, nearly equivalent, descriptions a and b (a hybrid of two) are not favored by the localization.

bonds, best described as fractional three-center bonds (Figure 7c), avoiding the more conventional possibilities (Figure 7a or 7b). We designate dotted legs in the central three-center bond toward the atom (B_2) which appears to have five bonds, including the terminal H atom. However, the exclusion principle is not violated, because only fractions of an atomic orbital are used in these bonds. Atomic populations are 0.74 on B_1 , 0.50 on B_2 , and 0.65 on B_3 (or B_6) from each of the fractional bonds. The bonding relationships shown in Figures 7a, 7b and 7c among these four atoms will emerge as a general principle for fractional three-center bonds below. The high value of 24% for d for the $B(1)$ - $B(2)$ bond in B_6H_{10} may be a symptom of this change in bonding as one goes to the carborane $C_2B_4H_8$.

Localization in B_5H_9 is ambiguous, yielding two different results depending upon the starting orbitals.¹⁹ It is therefore recommended that localization should be carried out only after the starting set has been subjected to unitary transformations based upon random numbers. In set A, Table I, the $B(1)$ - $B(2)$ - $B(3)$ bond is central three-center, while the $B(1)$ - $B(5)$ and $B(1)$ - $B(4)$ bonds are nearly single bonds. Set B has a single $B(1)$ - $B(4)$ bond, and fractional three-center bonds $B(1)$ - $B(2)$ - $B(3)$ and $B(1)$ - $B(5)$ - $B(2)$ as shown in Figure 8. All of these bonds have a d percentage of about 22. We refer below to this occurrence of fractional three-center bonds when

(25) M. D. Newton and E. Switkes, *J. Chem. Phys.*, **54**, 3179 (1971).

(26) I. R. Epstein, J. A. Tossell, E. Switkes, R. M. Stevens, and W. N. Lipscomb, *Inorg. Chem.*, **10**, 171 (1971).

(27) D. S. Marynick and W. N. Lipscomb, *J. Amer. Chem. Soc.*, in press.

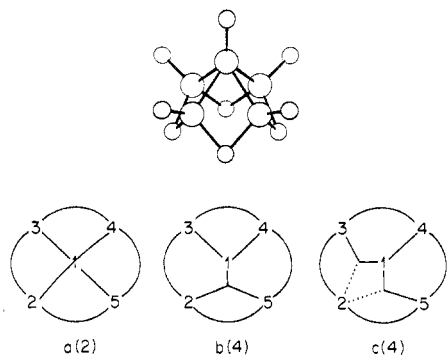
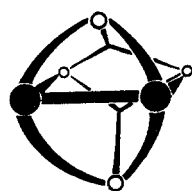

Figure 8. B_5H_9 . Localized structures b and c are obtained upon localizing from different randomized sets of orthogonal molecular orbitals, but structure a is not favored. The full molecular symmetry (C_{4v}) is obtained from the number of equivalent resonance hybrids indicated in parentheses.



1,2- $C_2B_4H_6$

Figure 9. Localized orbitals in 1,2- $C_2B_4H_6$. Open three-center bonds pass through the carbon atoms, which are also joined by a single bond. The topology is 0430, indicating no bridge hydrogens, four three-center bonds, three single bonds, and no BH_2 groups.

Table I
Localized Framework Orbitals in B_5H_9

Atoms		Populations		
Set A	B(1)-B(2)-B(3)	0.71	0.63	0.65
	B(1)-B(5)-B(2)	0.71	0.85	0.33
	B(1)-B(3)-B(4)	0.71	0.31	0.86
Set B	B(1)-B(2)-B(3)	0.71	0.55	0.72
	B(1)-B(5)-B(2)	0.71	0.81	0.42
	B(1)-B(3)-B(4)	0.72	0.23	0.88

high symmetry is present, and when the number of bonding pairs does not match the order of a principal axis of the molecule.

The 1,2- $C_2B_4H_6$ structure localizes beautifully to the unique valence structure²⁸ shown in Figure 9. The open three-center bond has, so far, been found by these localization procedures only when C is the middle atom. The orbital on C is almost pure π , so that the bonding open three-center orbital changes sign at the C atom.

The ideas of these last three paragraphs are partially summarized in the principle shown in Figure 10. Of the many bonding situations where one might expect fractional three-center bonds, we consider only a few, including now $B_{10}H_{14}$ and $B_{10}H_{14}^{2-}$.

The predicted²⁹ LMO structure (Figure 11c) for $B_{10}H_{14}$ avoids the problems associated earlier with the 24 resonance structures³⁰ or with the open three-

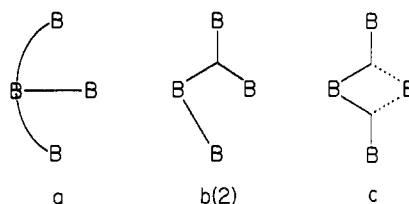

Figure 10. One important principle of near-equivalence of bond types. Structure a is favored only if the atom at the middle of the three-center bond is carbon, and usually structure c is favored over a or the hybrid (b) when all atoms are boron, as suggested above for 4,5- $C_2B_4H_8$ and B_5H_9 .

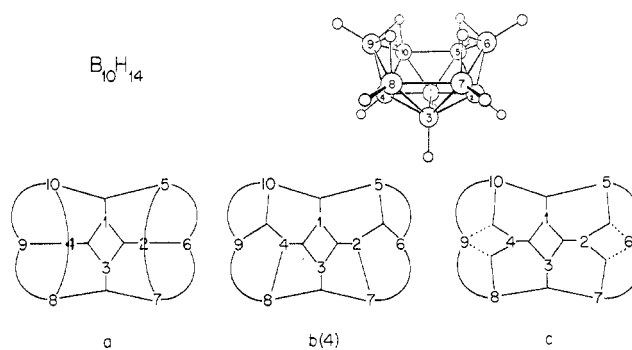

Figure 11. $B_{10}H_{14}$. (c) The favored localized valence structure extrapolated from structure a or the hybrid (b) using the general principle shown in Figure 10. This localized structure is an excellent approximation to a localized orbital analysis of a wave function for $B_{10}H_{14}$ obtained by the INDO method.

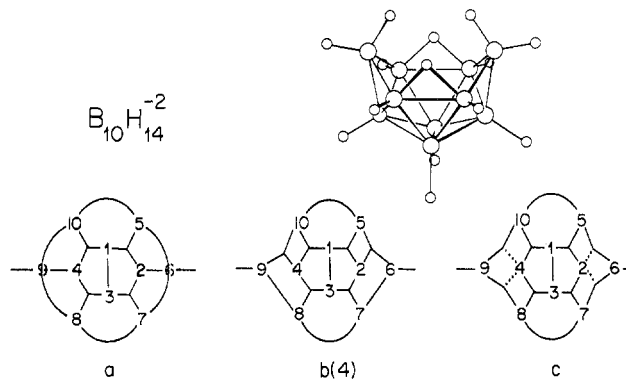

Figure 12. $B_{10}H_{14}^{2-}$. Valence structure a or the hybrid (b) extrapolate using the principle of Figure 10 to the favored valence structure (c).

center BBB bonds²³ (Figure 11a). This unique LMO structure has recently been found by localization of an INDO wave function.³¹ The reactive orbitals of the new SCF wave function²⁹ for $B_{10}H_{14}$ are consistent with preferred electrophilic attack at B(2) (B(4)), then at B(1) (B(3)), then at B(5) (B(7)), B(8), B(10), and finally at B(6) (B(9)). This order, and the reverse order for nucleophilic attack, would apply only if the transition state is dominated by the ground-state wave function. Most substitution reactions agree with these theoretical results.

Using the same principle (Figure 10) we predict³² fractional three-center bonds for $B_{10}H_{14}^{2-}$ (Figure 12c). Again, we can avoid a hybrid of 24 valence structures.² If $B_{10}H_{14}^{2-}$ had the hydrogen arrangement of $B_{10}H_{14}$, or conversely, there would be only

(28) I. R. Epstein, D. S. Marynick, and W. N. Lipscomb, *J. Amer. Chem. Soc.*, **95**, 1760 (1973).

(29) E. A. Laws, R. M. Stevens, and W. N. Lipscomb, *J. Amer. Chem. Soc.*, **94**, 4467 (1972).

(30) W. N. Lipscomb, *Pure Appl. Chem.*, **29**, 493 (1972).

(31) M. D. Newton, private communication, 1972.

(32) D. S. Kendall and W. N. Lipscomb, *Inorg. Chem.*, **12**, 546 (1973).

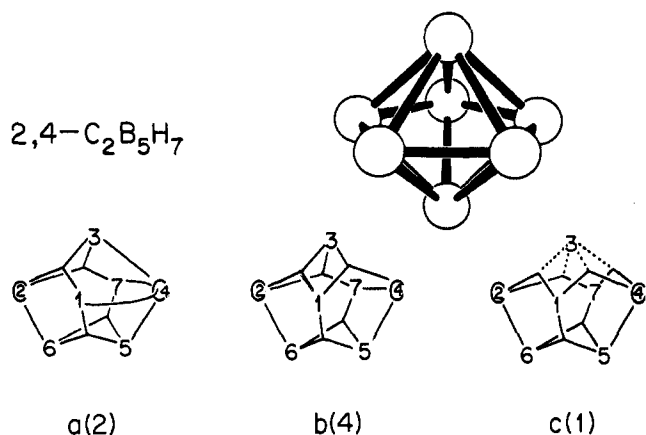

Figure 13. 2,4-C₂B₅H₇. This compact structure localizes surprisingly well to the fractional three-center bond description c, which has approximate equivalents in the less favored hybrids a and b.

one three-center bond structure. Thus, the preferred, but different, H arrangements in B₁₀H₁₄ and B₁₀H₁₄²⁻ are perhaps related to a resonance stabilization when described by central three-center bond theory. An alternative statement is that a geometrical structure having a fractional three-center bond description is probably preferred over an isomeric structure having a very small number of central three-center valence structures. The substitution chemistry of B₁₀H₁₄²⁻ is almost unknown, because its reactions are dominated by electron loss, consistent with the effect of electron repulsions in raising all SCF eigenvalues by about 0.4 au over those in B₁₀H₁₄.³³

A carborane of low symmetry, 2,4-C₂B₅H₇ (C_{2v}), has a simple and symmetrical LMO result. The four fractional bonds dotted toward B(3) (Figure 13c) are most simply related to equivalent descriptions (Figures 13a and 13b) which are only a small fraction of possible resonance structures. The SCF wave function³⁴ suggests nucleophilic reactivity first at B(3), then at B(1), and finally at B(5). The reverse order applies to electrophilic substitution. We note that B(5) is attached to only one C, while B(3) and B(1) are attached to two C atoms. Of B(3) and B(1) the former has fewer neighbors.³⁵

More symmetrical structures give rather complex LMO descriptions. In 1,6-C₂B₄H₆ (D_{4h})²⁸ the number of framework pairs (seven) does not match the rotational order (eight). Hence, localization to a single valence structure is not possible. In hypothetical B₄H₄ (T_d) the electron density has tetrahedral symmetry, of course, but the framework LMO's surprisingly tend to localize as rather unsymmetrical central three-center bonds.³⁶ However, the nonexistence of this compound is probably associated with a vacant molecular orbital than with this pathological localization.

More efficient localization procedures may allow the study of more complex boranes and carboranes. Until then, an acceptable procedure is to use the

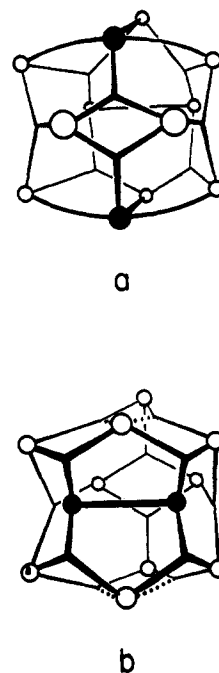

Figure 14. Three-center localization guesses for 1,7-C₂B₁₀H₁₂ in structure a and 1,2-C₂B₁₀H₁₂ in b. Structure b is the reversed diagram of a modified at the top and bottom to use fractional three-center bonds in b in place of the single bond and open three-center bond at carbon in a.

principles of the studies here, in conjunction with a complete search for appropriate standard three-center bond structures, in order to discover the most appropriate bond representation in a molecule or a reaction intermediate. An example of a prediction is shown in Figure 14 for *m*-C₂B₁₀H₁₂ and *o*-C₂B₁₀H₁₂.

We are now attempting to study LMO's and reaction pathways in the initial stages of the pyrolysis of B₂H₆. The near-Hartree-Fock limit for the 2BH₃ to B₂H₆ reaction is -19.0 kcal obtained from an extended Slater basis set.³⁷ An appropriate correlation correction has not been made, but the single and double excitations from a minimum Slater basis set give a correlation correction of -10.6 kcal. A recent experimental value is -35.5 kcal for ΔH_f. So far, the best transition state is centrosymmetric, having two very unsymmetrical bridge hydrogens, only slightly distorted BH₃ units, a B...B distance of 3.0 Å, and an energy greater than 2BH₃'s by 2.6 kcal (Figure 15). The LMO's show very little three-center bonding in this transition state.³⁸ Further studies are in progress on B₃H₇ (Figure 16), B₃H₉, B₄H₈, B₄H₁₂, and of course on the stable hydrides produced in these reactions.

Summary

(a) No open three-center bonds have been found in localized molecular orbitals of boranes.

(b) Carboranes, but not boranes, may have open three-center bonds, where C is the central atom, and may have an adjacent pair of C atoms (or an adjacent B and C) joined by both a single bond and a central three-center bond.

(33) D. S. Marynick, J. H. Hall, Jr., and W. N. Lipscomb, to be published.

(34) D. S. Marynick and W. N. Lipscomb, *J. Amer. Chem. Soc.*, in press.

(35) J. A. Potenza and W. N. Lipscomb, *Inorg. Chem.*, **5**, 1301 (1966).

(36) J. H. Hall, Jr., I. R. Epstein, and W. N. Lipscomb, *Inorg. Chem.*, **12**, 915 (1973).

(37) J. H. Hall, Jr., D. S. Marynick, and W. N. Lipscomb, *Inorg. Chem.*, **11**, 3126 (1972).

(38) I. R. Pepperberg, D. A. Dixon, and W. N. Lipscomb, to be published.

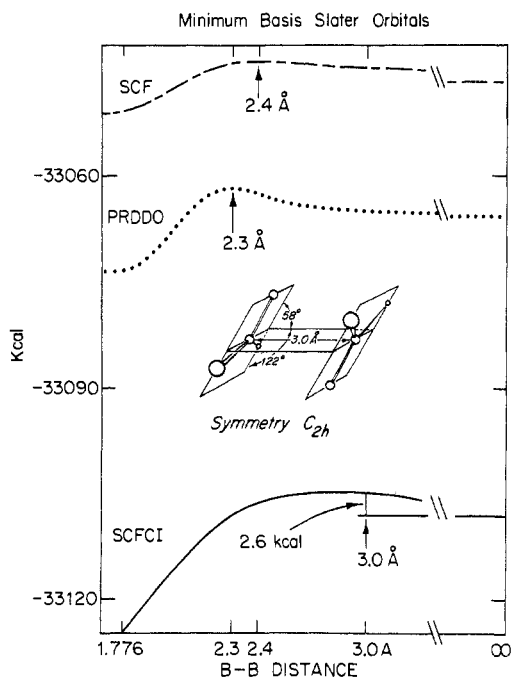

Figure 15. The formation of B_2H_6 from two BH_3 molecules, as a function of the $B \cdots B$ distance. The favored transition state has symmetry C_{2h} and consists of BH_3 units which are nearly planar with nearly equal BH bond lengths and which are less stable than two isolated BH_3 's by 2.6 kcal. For the PRDDO method see ref 8.

(c) Unique preferred three-center bonds exist in valence structures of B_2H_6 , B_4H_{10} , B_5H_{11} , B_6H_{10} , and $1,2-C_2B_4H_6$.

(d) Structures for which three-center bonds can be drawn are preferred over those which cannot be so expressed. For example, $B_{11}H_{11}^{2-}$ of C_{2v} symmetry is preferred over the C_{5v} structure.

(e) Of alternative geometries for an isomer, the structure having the larger number of nearly equivalent three-center bond structures is preferred. This argument takes precedence over which choice has the more favorable charge distribution.

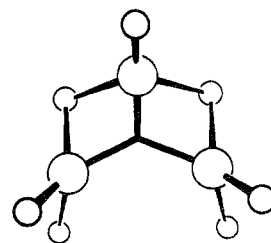

Figure 16. Hypothetical geometrical and valence structure for B_3H_7 .

(f) Unique fractional three-center bond descriptions exist for $4,5-C_2B_4H_8$ and probably also for $B_{10}H_{14}$, $B_{10}H_{14}^{2-}$, and $B_9H_{13}L$.

(g) Fractional three-center bonds occur replacing an open three-center bond and a single bond from the central atom to a fourth atom, except when C is the central atom.

(h) It is probable that valence structures having a vacant orbital which can easily be incorporated into three-center bond structures are preferred over those which cannot.

In more general terms we see now differences in the valence rules as they apply to boron and carbon in the boranes and carboranes. In addition to the early objectives of deciding what stable "electron-deficient" species are stable in the sense that all orbitals are filled to the valence level, we now hope that a hierarchy of rules at different levels of detail can be derived from rigorous self-consistent field methods in such a way that charge distributions, reaction intermediates, and reaction pathways can be found.

It is a pleasure to acknowledge all coauthors of this research as shown in the references, most recently I. R. Epstein, T. A. Halgren, J. H. Hall, Jr., E. A. Laws, D. S. Marynick, M. D. Newton, I. Pepperberg, R. M. Stevens, and E. Switkes, and to acknowledge support of this research by the Office of Naval Research and the National Institutes of Health.